

**Fire/Heat Test Generally in Accordance
with BS 7346: Part 3: 1990,
Clause 4.1, on a Fabric Smoke Curtain**

Test Sponsor

Bradley Lomas Electrolok Ltd







**Fire/Heat Test Generally in Accordance
with BS 7346: Part 3: 1990,
Clause 4.1, on a Fabric Smoke Curtain**

Test Sponsor

Bradley Lomas Electrolok Ltd
Manor House, Church street
Eckington
Sheffield
S31 9BH

Issue 2: Amendments to text.

	Name	Signature*
Responsible Officer	S. Baker	
Approved	D. Hankinson	

* For and on behalf of Warrington Fire Research Centre.

Report Issued : 4th March 2002

This is Copy No. 3 of Test Report WARRES No. 121880 which has been issued at the request of the sponsor.

This copy has been produced from a .pdf format electronic file that has been provided by Warrington Fire Research Centre to the sponsor of the report and must only be reproduced in full. Extracts or abridgements of reports must not be published without permission of Warrington Fire Research Centre. The original signed paper version of this report, which also includes a silvered logo, is the sole authentic version. Only original paper versions of this report bear authentic signatures of the responsible Warrington Fire Research Centre staff.



**Fire/Heat Test Generally in Accordance
with BS 7346: Part 3: 1990,
Clause 4.1, on a Fabric Smoke Curtain**

Summary

A specimen of fabric smoke curtain assembly has been subjected to a test performed generally in accordance with BS 7346: Part 3: 1990, Clause 4.1, with the exception that the furnace temperature was controlled to follow, as closely as possible, the temperature/time curve given in BS 476: Part 20: 1987.

The assembly briefly comprised a tubular steel barrel within a steel enclosure hood, the barrel supporting a fabric curtain. The curtain was 2820 mm wide and had a height, including barrel and enclosure, of 3000 mm. A load, in the form of steel weights, was applied to the bottom bar of the assembly to simulate a curtain drop of 6 m. The curtain was installed such that it was not supported by the floor.

The specimen satisfied the performance requirements specified BS 7346: Part 3, Clause 4.1, for the full 67 minute test duration.

Date of Test : 22nd January 2002

Contents

	Page
Summary	3
Contents	4
Purpose of the test	5
Introduction	5
Test specimen construction	5
Instrumentation and measuring equipment	5
Test procedure	6
Test data and information	6
Evaluation against the performance criteria	6
Conclusions	6
Limitations	7
Review	7
 Annexes	
Annex A Schedule of components	8
Annex B Data recorded during test	13
Annex C Observations on the general behaviour of the specimen during the test	19
Annex D Photographs	20

1 **Purpose of the Test**

- 1.1 To determine the performance of a fabric smoke curtain assembly, generally in accordance with BS 7346: Part 3: 1990.

2 **Introduction**

- 2.1 The specimen was a fabric smoke curtain and the test was conducted generally in accordance with BS 7346: Part 3: 1990 'Specification for smoke curtains'. This test report should be read in conjunction with that Standard and with BS 476: Part 20: 1987, 'Methods for determination of the fire resistance of elements of construction (general principles)'. The test was conducted generally in accordance with the standard as the temperature requirements were controlled to conform to with the temperature/time curve given in BS 476: Part 20: 1987.
- 2.2 The specimen was judged on its ability to comply with the performance criteria, as required by BS 7346: Part 3: 1990, Clause 4.1.
- 2.3 Certain aspects of some fire test specifications are open to different interpretations. The Fire Test Study Group has identified a number of such areas and has agreed Resolutions, which define common agreement of interpretations between fire test laboratories, which are members of the Group. Where such Resolutions are applicable to this test they have been followed.
- 2.4 The test was conducted on the 22nd January 2002 at the request of Bradley Lomas Electrolok Ltd, the sponsor of the test.
- 2.5 The test was witnessed by representatives of the test sponsor.

3 **Test Specimen Construction**

- 3.1 A comprehensive description of the test construction is given in Annex A. The description is based on a detailed survey of the specimen and information supplied by the sponsor of the test.
- 3.2 The specimen was supplied in component form by the sponsor on the 21st January 2002. Warrington Fire Research Centre was not involved in any selection or sampling procedures of the components.
- 3.3 The specimen was installed into a refractory concrete lined steel support frame by representatives of the sponsor on the 21st January 2002.

4 **Instrumentation and Measuring Equipment**

- 4.1 The instrumentation was provided in accordance with the requirements of the Standard.
- 4.2 Nine thermocouples, distributed over a plane 100 mm from the surface of the test construction, were provided to monitor the temperature of the furnace atmosphere.
- 4.3 Pressure sensors were provided within the furnace to monitor the furnace atmospheric pressure.

- 4.4 A water-cooled foil heat-flux meters was used to record the heat radiation from the specimen. The heat flux meter was positioned at a distance of 3565 mm from the unexposed surface of the specimen.

5 **Test Procedure**

- 5.1 The test was conducted generally in accordance with the procedure specified in BS 7346: Part 3: 1990, Clause 4.1.
- 5.2 The furnace was controlled so that its mean temperature complied as closely as possible with the requirements of BS 476: Part 20: 1987, Clause 3.1.
- 5.4 Throughout the test the temperatures indicated by the thermocouples provided to monitor the furnace were continuously monitored and were recorded at one minute intervals.
- 5.5 The thermocouples referred to in 4.2 were used to determine the mean furnace temperature.

6 **Test Data and Information**

- 6.1 The following data, which was recorded during the test, is given in Annex B:
- 6.1.1 Mean furnace temperature, together with the temperature/time relationship specified in BS 476: Part 20: 1987.
- 6.1.2 The mean and individual temperatures recorded by the thermocouples fixed to the unexposed surface of the fabric.(Thermocouples 2 to 6)
- 6.1.3 Individual temperatures recorded on the unexposed surface of the head box and the unexposed surface of the fabric at a joint position. (Thermocouples 7 and 8).
- 6.1.4 Recorded radiation intensity.
- 6.2 A summary of the observations made on the general behaviour of the specimen during the test is given in Annex C.
- 6.3 The ambient air temperature in the vicinity of the test construction was 15°C at the start of the test with a maximum variation of +3°C, during the test.
- 6.4 Photographs of the specimen taken before, during and after the test are included in Annex D.
- 6.5 The test was discontinued after a period of 67 minutes.

7 **Evaluation against the Performance Criteria**

- 7.1 The specimen remained in place and intact for the full 67 minutes duration of the test.

8 **Conclusions**

8.1 A specimen of a fabric smoke curtain assembly has been subjected to a fire/heat test generally in accordance with BS 7346: Part 3: 1990, Clause 4.1.

8.2 The specimen remained in place and intact for the full 67 minutes duration of the test.

9 **Limitations**

9.1 The results relate only to the behaviour of the specimen of the element of construction under the particular conditions of test. They are not intended to be the sole criteria for assessing the potential fire performance of the element in use, nor do they reflect the actual behaviour in fires.

10 **Review**

10.1 The specification and interpretation of fire test methods are the subject of ongoing development and refinement. Changes in associated legislation may also occur. For these reasons it is recommended that the relevance of test reports over five years old should be considered by the user. The laboratory that issued the report will be able to offer, on behalf of the legal owner, a review of the procedures adopted for a particular test to ensure that they are consistent with current practices, and if required may endorse the test report.

4th March 2002

Annex A

Schedule of Components

(Refer to Figures 1 to 3)

(All values are nominal unless stated otherwise)

(All other details are as stated by the sponsor)

Item	<u>Description</u>
1. Head Box	
Manufacturer	: Bradley Lomas Electrolok Limited
Material	: Galvanised mild steel
Thickness	: 1.2 mm
Overall size	: 150 mm x 150 mm, with 2 mm thick end plates
Fixing method	: Using a twin row of M10 set screws through 6 mm thick 40 mm x 40 mm steel washers into Hilti HKD flush anchors at 1000 mm centres.
2. Head Box Sliding Bracket	
Manufacturer	: Bradley Lomas Electrolok Limited
Material	: Galvanised mild steel
Thickness	: 1.2 mm
Overall size	: 147 mm x 147 mm
Fixing method	: Fitted inside head box sections, riveted to one and held using M6 set screws with hexagonal nuts through slotted holes in bracket to the other.
3. Roller Mechanism	
Material	: Steel octagonal tube incorporating SD3 24 volt motor assembly and support bearing
Thickness	: 1.2 mm
Diameter	: 70 mm
Length	: 2945 mm
Fixing method	: Via 2 mm galvanised steel top-fix brackets incorporating steel motor support brackets fixed with M6 set screws. The assemblies are secured to the top of the head box using M6 set screws with hexagonal nuts.
4. Curtain	
Manufacturer	: Bradley Lomas Electrolok Limited
Material	: Glass cloth
Reference	: X32K
Thickness	: 0.40 mm
Weight	: 440 g/m ²
Coating	: Silver polyurethane to both sides
Fixing methods	
i. head	: Secured to roller via steel fixing strip 20 mm x 3 mm wide within a reinforced pocket hem
ii. vertical joints	: Over lapped by 50 mm and sewn with two rows of stainless steel thread 30 mm apart

Annex A (Continued)**Item****Description****5 Bottom Bar Assembly**

Material	:	Mild steel angles, two fitted back to back.
Thickness	:	3 mm
Overall size	:	20 mm x 20 mm
Fitting method	:	M6 countersunk screws, inserted through one angle and curtain fabric and secured into tapped holes in the other angle at 250 mm centres
Additional weight	:	Mild steel plates 16 mm x 3 mm were rivet fixed to angles on each side of curtain.

6. Cover Plate (Removable)

Manufacturer	:	Bradley Lomas Electrolok Limited
Material	:	Galvanised mild steel
Thickness	:	1.2 mm
Overall size	:	117 mm x 20 mm returned leg
Fixing method	:	Using 16 mm long x 4.6 mm diameter self tapping screws at 300 mm centres

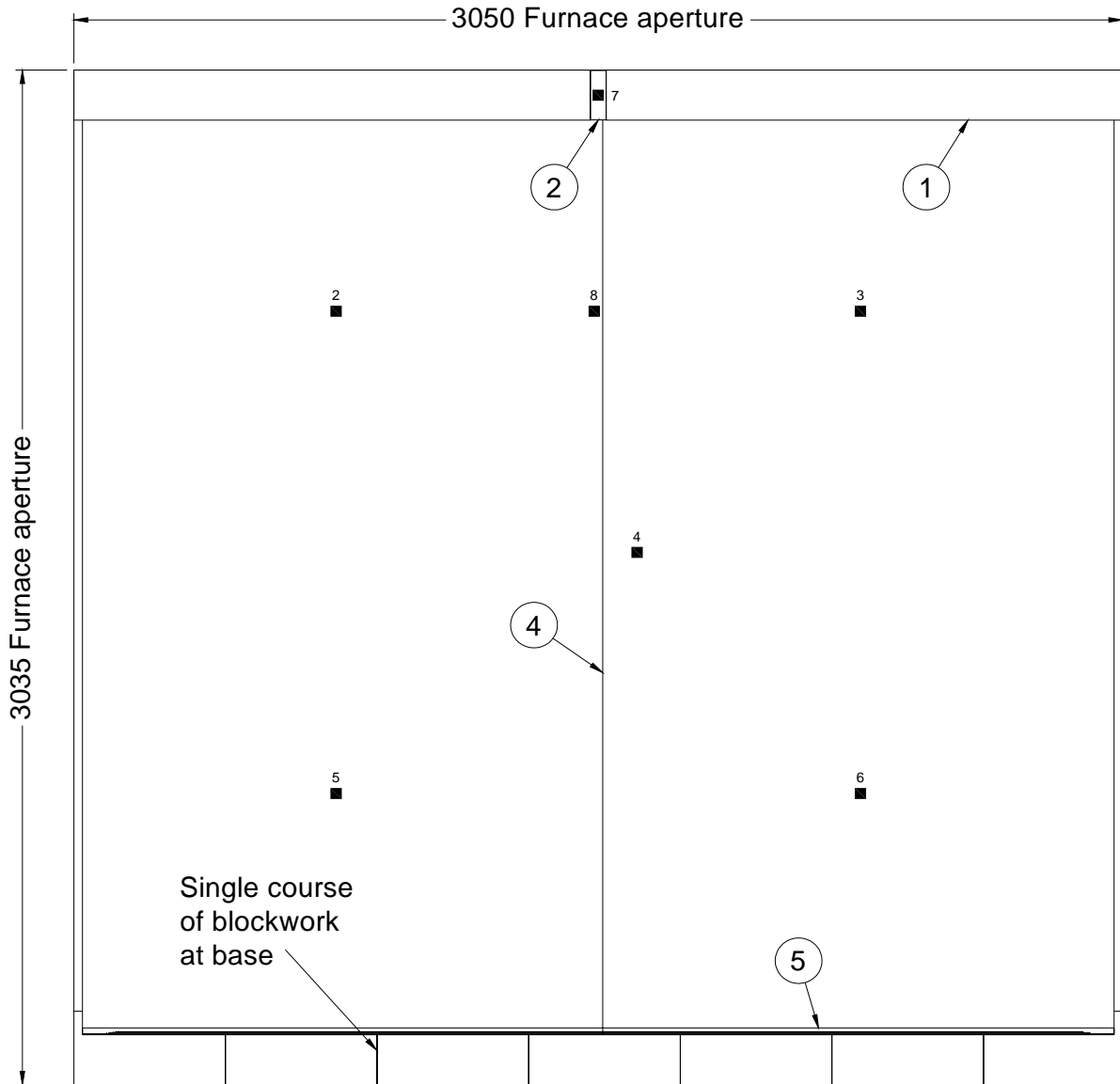

GENERAL ELEVATION

■ Positions of thermocouples.

Do not scale

See Annex A for schedule.
All dimensions are in mm.

FIGURE 1

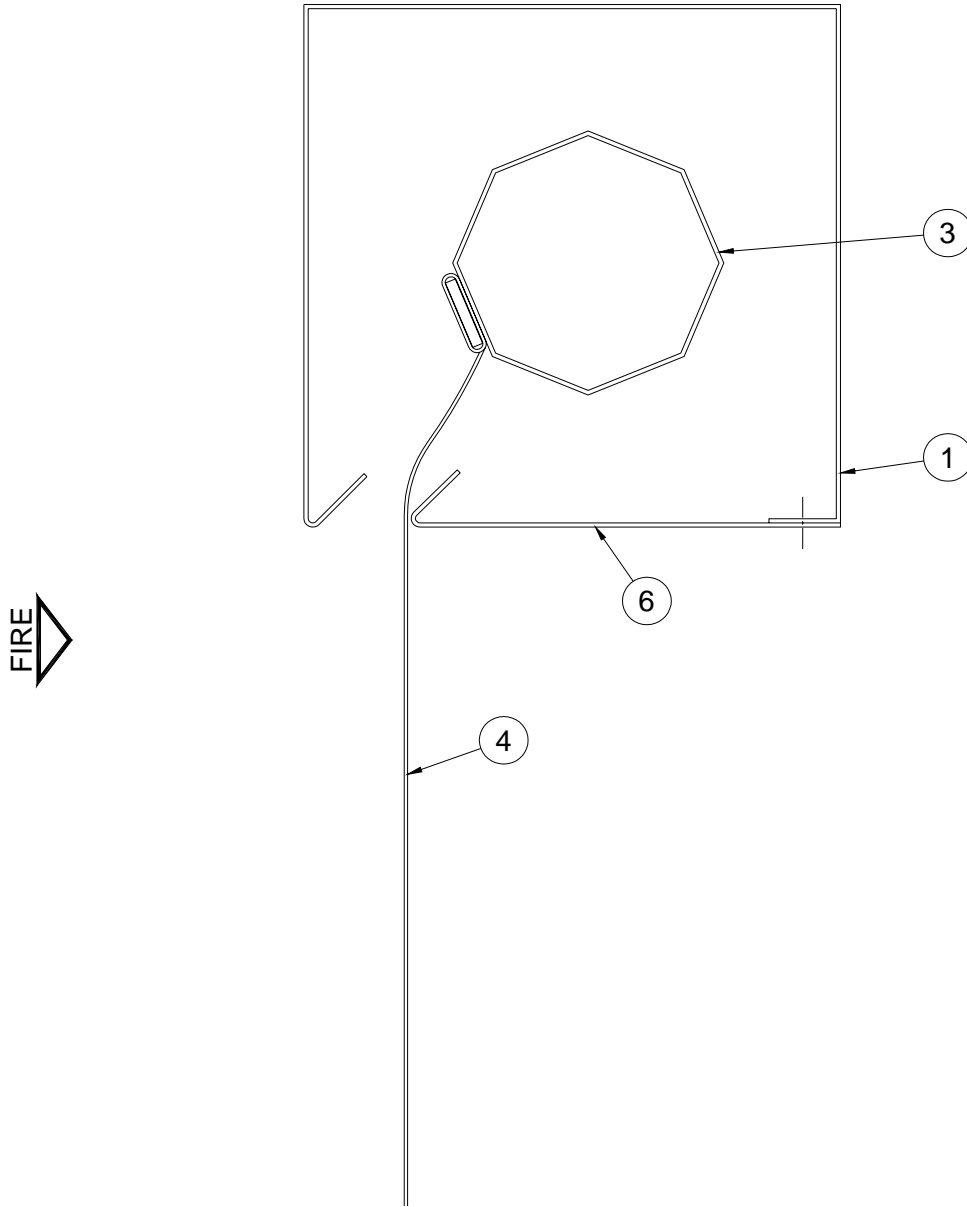

VERTICAL SECTION
THROUGH HEADER

Do not scale

See Annex A for schedule.
All dimensions are in mm.

FIGURE 2

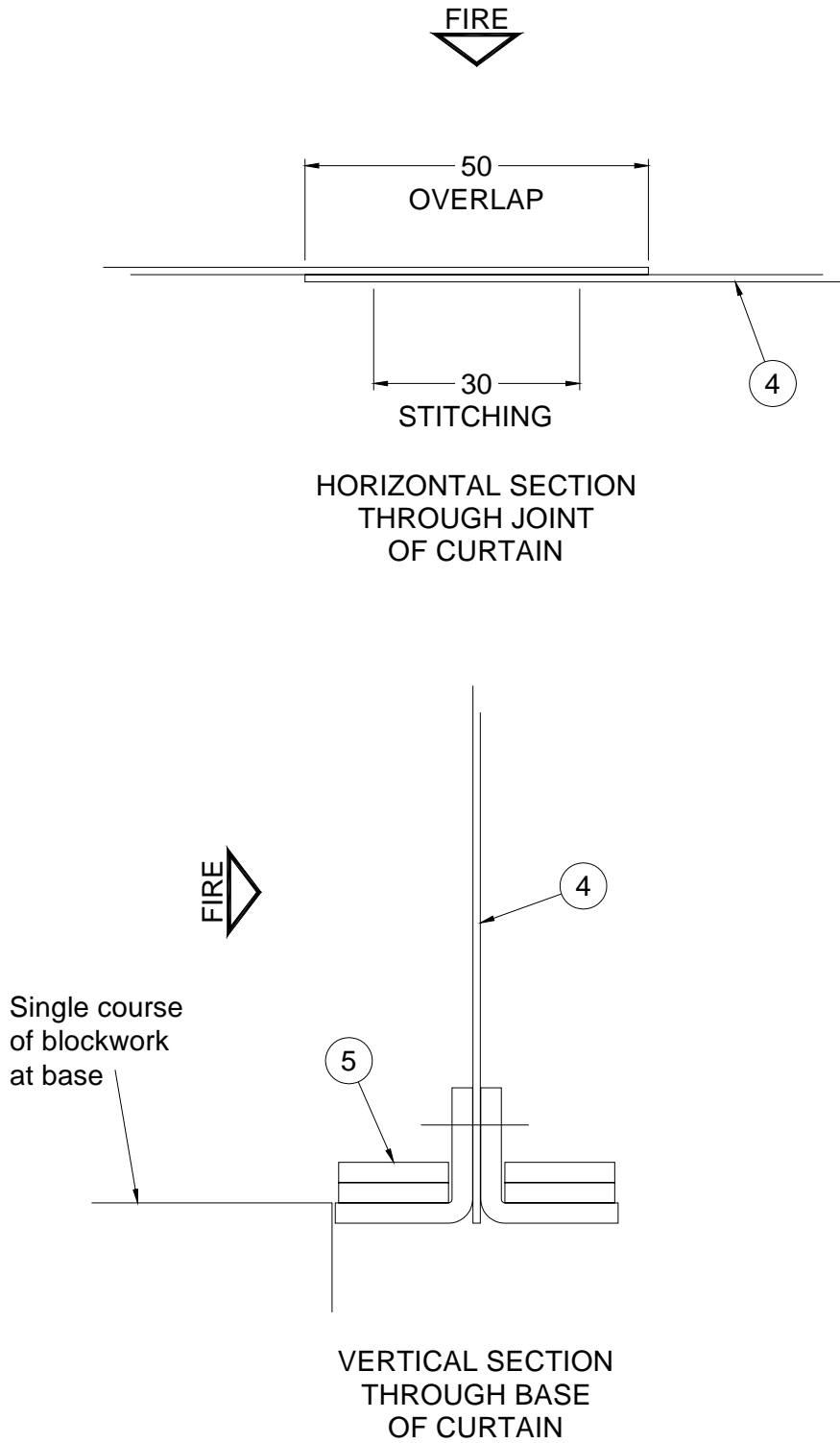

Do not scale

See Annex A for schedule.
All dimensions are in mm.

FIGURE 3

Annex B

Data Recorded During the Test

Table 1

Specified and Actual Furnace Temperatures

Time Minutes	Specified Furnace Temperature Deg.C	Actual Furnace Temperature Deg.C
0	20	29
2	445	432
4	544	547
6	603	596
8	645	632
10	678	673
12	705	708
14	728	733
16	748	751
18	766	763
20	781	782
22	796	796
24	809	806
26	820	816
28	832	836
30	842	842
32	851	844
34	860	861
36	869	866
38	877	877
40	885	887
42	892	890
44	899	899
46	906	908
48	912	914
50	918	921
52	924	919
54	930	928
56	935	927
58	940	944
60	945	942
62	950	953
64	955	958
66	960	961
67	962	967

Annex B (Continued)**Table 2**

Individual and Mean Temperatures Recorded From Unexposed Face of the Specimen

Time Minutes	T/C Number 2 Deg.C	T/C Number 3 Deg.C	T/C Number 4 Deg.C	T/C Number 5 Deg.C	T/C Number 6 Deg.C	Mean Temperature Deg.C
0	23	23	23	21	22	22
2	199	209	161	133	135	167
4	321	332	248	194	203	260
6	405	401	312	252	270	328
8	431	391	376	302	317	363
10	428	400	441	333	344	389
12	465	452	444	428	448	447
14	492	467	467	407	415	450
16	510	488	477	410	425	462
18	518	495	488	428	442	474
20	545	506	510	454	471	497
22	560	517	526	462	485	510
24	566	516	534	470	488	515
26	583	526	547	476	492	525
28	598	550	567	457	509	536
30	616	561	581	478	518	551
32	625	580	600	473	529	561
34	633	598	614	509	550	581
36	644	611	625	526	564	594
38	654	622	635	538	577	605
40	666	633	648	550	591	618
42	674	636	654	562	605	626
44	685	647	664	579	623	640
46	694	653	672	597	633	650
48	701	659	674	595	628	651
50	715	675	686	602	636	663
52	717	667	684	625	640	667
54	726	681	694	625	654	676
56	732	693	701	632	661	684
58	740	695	705	625	662	685
60	751	698	708	650	665	694
62	758	700	710	672	669	702
64	762	706	714	666	673	704
66	766	711	723	677	683	712
67	771	715	730	674	688	716

Annex B (Continued)

Table 3

Individual Temperatures Recorded From Unexposed Face of the Specimen

Time Minutes	T/C Number 7 Deg.C	T/C Number 8 Deg.C
0	24	23
2	58	208
4	99	300
6	144	368
8	194	454
10	236	424
12	276	472
14	311	503
16	349	518
18	381	531
20	396	546
22	410	562
24	421	566
26	428	585
28	451	606
30	476	622
32	494	638
34	514	649
36	522	657
38	526	666
40	532	677
42	538	684
44	544	694
46	552	699
48	557	708
50	575	720
52	583	714
54	592	725
56	600	736
58	609	742
60	614	744
62	619	749
64	622	753
66	623	760
67	627	765

Annex B (Continued)

Table 5

Recorded Radiation Intensity

Time Minutes	Radiation Intensity at 3565mm Kw/m
0	0.00
2	0.14
4	0.31
6	0.40
8	0.51
10	0.68
12	0.88
14	0.79
16	0.99
18	0.93
20	1.07
22	1.21
24	1.10
26	1.27
28	1.33
30	1.53
32	1.53
34	1.64
36	1.72
38	1.75
40	2.01
42	2.06
44	2.23
46	2.43
48	2.40
50	2.54
52	2.63
54	2.77
56	2.97
58	3.05
60	3.08
62	3.22
64	3.19
66	3.33
67	3.39

Annex B (Continued)

Graph 1

Specified and Actual Furnace Temperatures

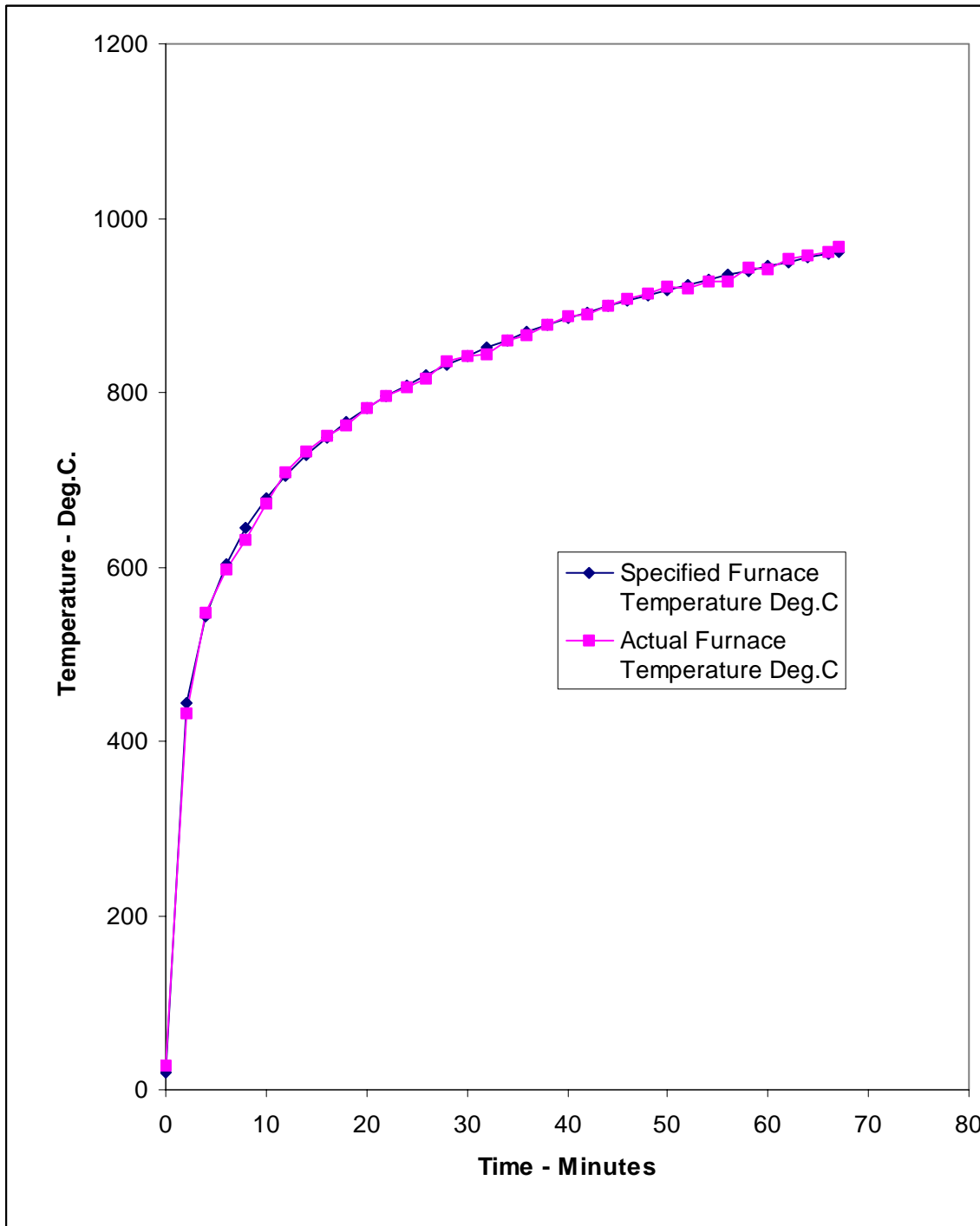

Annex B (Continued)

Graph 2

Mean Temperature Recorded from the Unexposed Face of the Specimen

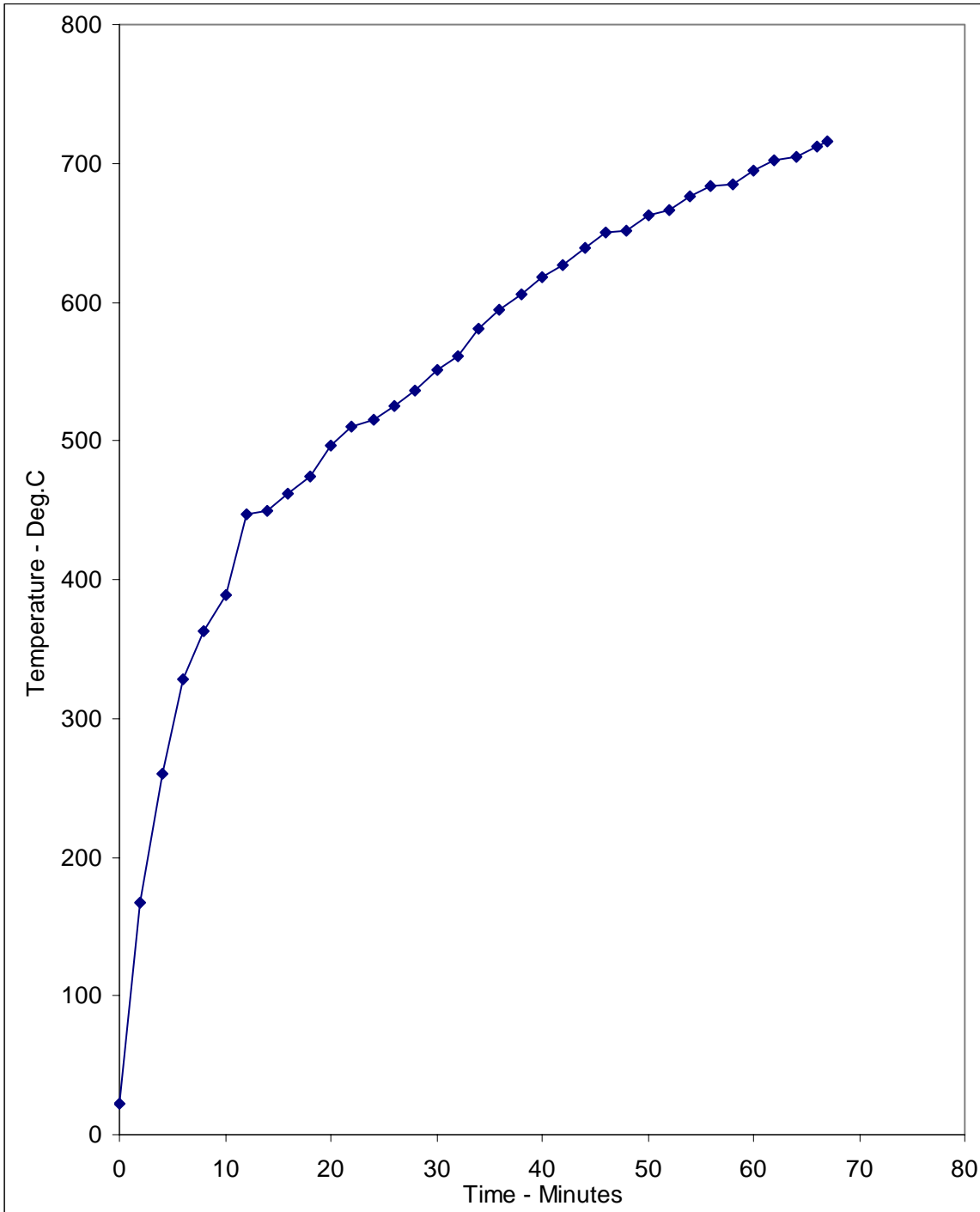

Annex C

Observations Made by the Responsible Officer

U – Observations made from unexposed side

E – Observations made from exposed side

Time			
<u>Mins</u>	<u>Secs</u>		
00	00		The Test Commences.
00	30	U	Smoke release commences from the top half of the specimen.
02	00	U	Continued smoke release from the top half of specimen.
04	10	U	Smoke release continues to increase from the specimen, slight discolouration of fabric.
06	50	U	The curtain continues to discolour, turning light brown at mid-height. Smoke release continues. The fabric has formed an 'S' shape as the top half bellows away from the heating conditions.
10	00	U	The smoke curtain has continued to discolour.
15	00	U	Continued smoke release. Curtain light brown in colour.
20	00	U	Smoke release has decreased. The head box has started to discolour slightly.
25	00	U	The bottom bar has bowed upwards slightly by approximately 5 – 10 mm.
30	00	U	No further significant visible change.
40	00	U	The head box has twisted slightly. The curtain is now silver in appearance.
50	00	U	The curtain has started to drop slightly, more prominently to the left hand side. approximately 15 – 20 mm drop maximum.
60	00	U	Curtain approximately 20 – 25 mm.
65	00	U	Curtain has dropped approximately 100 mm and increasing.
67	10	U	The curtain to the left hand side has ripped and come away from the head box. Through gap into the furnace is visible. The test is discontinued.

Annex D

Photographs

- Plate 1 - Exposed surface of the specimen before testing.
- Plate 2 - Unexposed surface of the specimen before testing.
- Plate 3 - Unexposed surface of the specimen during testing.
- Plate 4 - Unexposed surface of the specimen during testing.
- Plate 5 - Exposed surface of the specimen after testing.



Plate 1



Plate 2



Plate 3

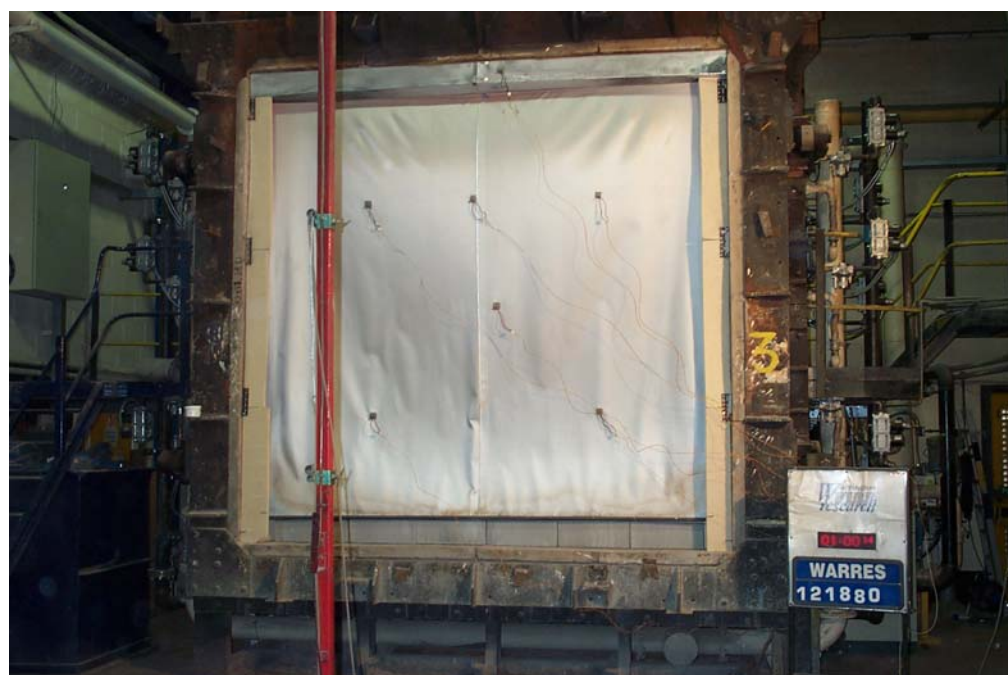

Plate 4



Plate 5